

---

### Rectifier Switch for Reverse Battery Connection

---

No. EA-320-1811214

#### OUTLINE

The R5590x is a rectifier switch, which allows the reverse connection of battery. This device can output the voltage rectified in either positive or negative polarity regardless of the polarity of the input voltage. Therefore, this device allows the various applications without being limited by the battery loading directions or the connector insertion directions. This device also protect the device system from the accidental reverse connection of battery.

A small loss resistance of typically 0.4  $\Omega$  (SON1612-6)/ 0.5  $\Omega$  (SOT-23-5) and a small supply current of typically 50 nA at 1.5 V input voltage make this device ideal for the applications using a battery.

For the applications using multiple batteries in series or in parallel, the output pin should also be connected in series or in parallel to rectify the power source and protect the device system.

This device is offered in a small 5-pin SOT-23-5 package or an ultra-small and thin 6-pin SON1612-6 package which achieves easy and the smallest possible footprint solutions on board where area is limited.

#### FEATURES

- Input Voltage Range (Maximum Rating) ..... 0.9 V to 5.25 V (6.0 V)
- Supply Current ..... Typ. 50 nA (Input Voltage 1.5 V)
- Loss Resistance ..... Typ. 0.4  $\Omega$  (Input Voltage 1.5 V, SON1612-6)  
Typ. 0.5  $\Omega$  (Input Voltage 1.5 V, SOT-23-5)
- Package ..... SON1612-6, SOT-23-5

#### APPLICATIONS

- Battery Driven Toys, Remote Controllers, Mouse
- Mobile Health Care Devices

---

**R5590x**

---

No. EA-320-181214

**SELECTION GUIDE**

The package is a user-selectable option.

**Selection Guide**

Product Name	Package	Quantity per Reel	Pb Free	Halogen Free
R5590D001A-TR-FE	SON1612-6	4,000 pcs	Yes	Yes
R5590N001A-TR-FE	SOT-23-5	3,000 pcs	Yes	Yes

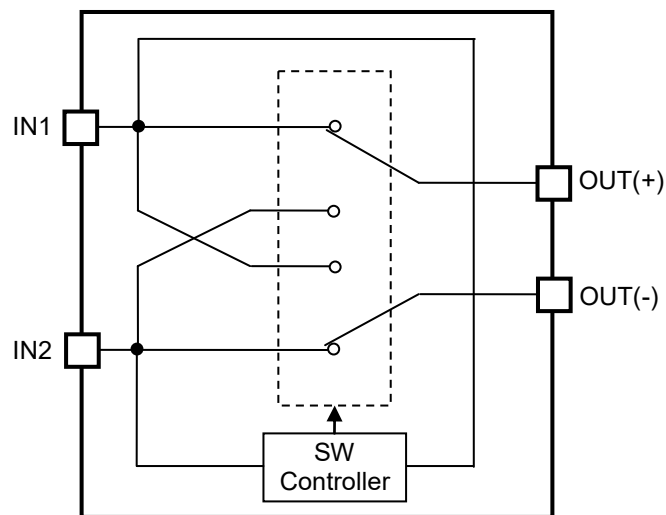
**BLOCK DIAGRAMS****R5590x001A Block Diagram**

## PIN DESCRIPTION

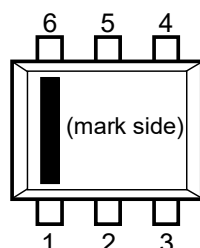

SON1612-6 Pin Configuration

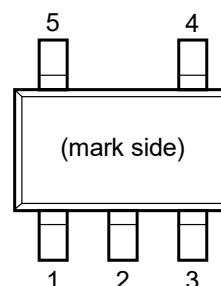

SOT-23-5 Pin Configuration

### SON1612-6 Pin Description

Pin No.	Symbol	Description
1	IN2	Input Pin 2
2	OUT (-)	Negative Output Pin <sup>(1)</sup>
3	NC	No Connection
4	IN1	Input Pin 1
5	OUT (-)	Negative Output Pin <sup>(1)</sup>
6	OUT (+)	Positive Output Pin

### SOT-23-5 Pin Description

Pin No.	Symbol	Description
1	IN1	Input Pin 1
2	OUT (-)	Negative Output Pin
3	NC	No Connection
4	IN2	Input Pin 2
5	OUT (+)	Positive Output Pin

<sup>(1)</sup> No. 2 pin and No. 5 pin must be wired together at mounting on a board.

---

**R5590x**

---

No. EA-320-181214

**ABSOLUTE MAXIMUM RATINGS****Absolute Maximum Ratings**

Symbol	Parameter		Rating	Unit	
$\Delta V_{IN}$	Input Pin Voltage Difference ( $ IN1 - IN2 $ )		6.0	V	
$\Delta V_{OUT}$	Output Pin Voltage ( $OUT(+) - OUT(-)$ )		0 to $\Delta V_{IN}$	V	
$I_{OUT}$	Output Current		400	mA	
$P_D$	Power Dissipation <sup>(2)</sup>	SON1612-6	Standard Test Land Pattern	500	mW
		SOT-23-5	JEDEC STD.51-7	660	
$T_j$	Junction Temperature Range		-40 to 125	°C	
$T_{stg}$	Storage Temperature Range		-55 to 125	°C	

**ABSOLUTE MAXIMUM RATINGS**

Electronic and mechanical stress momentarily exceeded absolute maximum ratings may cause the permanent damages and may degrade the life time and safety for both device and system using the device in the field. The functional operation at or over these absolute maximum ratings is not assured.

**RECOMMENDED OPERATING CONDITIONS****Recommended Operating Conditions**

Symbol	Parameter	Rating	Unit
$V_{IN}$	Input Voltage	0.9 ~ 5.25	V
$T_a$	Operating Temperature Range	-40 ~ 85	°C

**RECOMMENDED OPERATING CONDITONS**

All of electronic equipment should be designed that the mounted semiconductor devices operate within the recommended operating conditions. The semiconductor devices cannot operate normally over the recommended operating conditions, even if when they are used over such conditions by momentary electronic noise or surge. And the semiconductor devices may receive serious damage when they continue to operate over the recommended operating conditions.

---

<sup>(2)</sup> Refer to *POWER DISSIPATION* for detailed information.

---

## ELECTRICAL CHARACTERISTICS

The specifications surrounded by   are guaranteed by design engineering at  $-40^{\circ}\text{C} \leq T_a \leq 85^{\circ}\text{C}$ .

### R5590D001A Electrical Characteristics

(Ta = 25°C)

Symbol	Parameter	Test Conditions/Comments	Min.	Typ.	Max.	Unit	
$\Delta V_{\text{IN}}$	Input Pin Voltage Difference		<span style="border: 1px solid black; padding: 0 2px;">0.9</span>		5.25	V	
$R_{\text{ON}}$	Switch On Resistance	$V_{\text{IN}} = 1 \text{ V}, I_{\text{OUT}} = 100 \text{ mA}$		0.65	<span style="border: 1px solid black; padding: 0 2px;">1.40</span>	$\Omega$	
		$V_{\text{IN}} = 1.5 \text{ V}, I_{\text{OUT}} = 100 \text{ mA}$		0.40	<span style="border: 1px solid black; padding: 0 2px;">0.85</span>		
		$V_{\text{IN}} = 5.25 \text{ V}, I_{\text{OUT}} = 100 \text{ mA}$		0.30	<span style="border: 1px solid black; padding: 0 2px;">0.62</span>		
$I_{\text{SS}}$	Supply Current	$V_{\text{IN}} = 1.5 \text{ V}, I_{\text{OUT}} = 0 \text{ mA}$	$T_a = 25^{\circ}\text{C}$		0.05	$\mu\text{A}$	
		$V_{\text{IN}} = 5.25 \text{ V}, I_{\text{OUT}} = 0 \text{ mA}$	$T_a = 25^{\circ}\text{C}$		0.15		4.5
			$-40^{\circ}\text{C} \leq T_a \leq 85^{\circ}\text{C}$				<span style="border: 1px solid black; padding: 0 2px;">55</span>

All parameters listed under *ELECTRICAL CHARACTERISTICS* are done under the pulse load condition ( $T_j \approx T_a = 25^{\circ}\text{C}$ ).

### R5590N001A Electrical Characteristics

(Ta = 25°C)

Symbol	Parameter	Test Conditions/Comments	Min.	Typ.	Max.	Unit	
$\Delta V_{\text{IN}}$	Input Pin Voltage Difference		<span style="border: 1px solid black; padding: 0 2px;">0.9</span>		5.25	V	
$R_{\text{ON}}$	Switch On Resistance	$V_{\text{IN}} = 1 \text{ V}, I_{\text{OUT}} = 100 \text{ mA}$		0.75	<span style="border: 1px solid black; padding: 0 2px;">1.45</span>	$\Omega$	
		$V_{\text{IN}} = 1.5 \text{ V}, I_{\text{OUT}} = 100 \text{ mA}$		0.50	<span style="border: 1px solid black; padding: 0 2px;">0.88</span>		
		$V_{\text{IN}} = 5.25 \text{ V}, I_{\text{OUT}} = 100 \text{ mA}$		0.35	<span style="border: 1px solid black; padding: 0 2px;">0.65</span>		
$I_{\text{SS}}$	Supply Current	$V_{\text{IN}} = 1.5 \text{ V}, I_{\text{OUT}} = 0 \text{ mA}$	$T_a = 25^{\circ}\text{C}$		0.05	$\mu\text{A}$	
		$V_{\text{IN}} = 5.25 \text{ V}, I_{\text{OUT}} = 0 \text{ mA}$	$T_a = 25^{\circ}\text{C}$		0.15		4.5
			$-40^{\circ}\text{C} \leq T_a \leq 85^{\circ}\text{C}$				<span style="border: 1px solid black; padding: 0 2px;">55</span>

All test items listed under *ELECTRICAL CHARACTERISTICS* are done under the pulse load condition ( $T_j \approx T_a = 25^{\circ}\text{C}$ ).

## APPLICATION INFORMATION

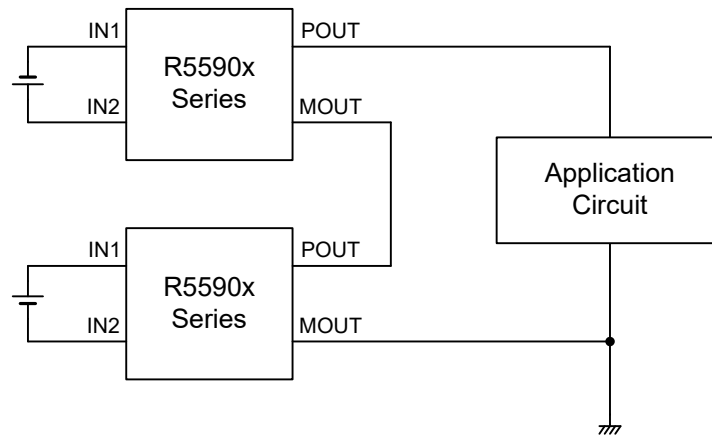

**Typical Rectification Circuit with 2 Serial Batteries**

## TECHNICAL NOTES

If the input voltage difference becomes less than output voltage difference, which could happen when the AC power source is rectified or the DC power source having different voltage is used in parallel, the current flows from the output side to the input side. To prevent this, use a reverse current prevention diode.

The short circuit current flows when the output pin is shorted while bias voltage is applied to the input pin. The R5590x should be operated within the absolute maximum ratings of each package.

## TYPICAL CHARACTERISTICS

Note: Typical Characteristics are intended to be used as reference data; they are not guaranteed.

### 1. Output Current vs. Output Pin Voltage (Ta = 85°C)

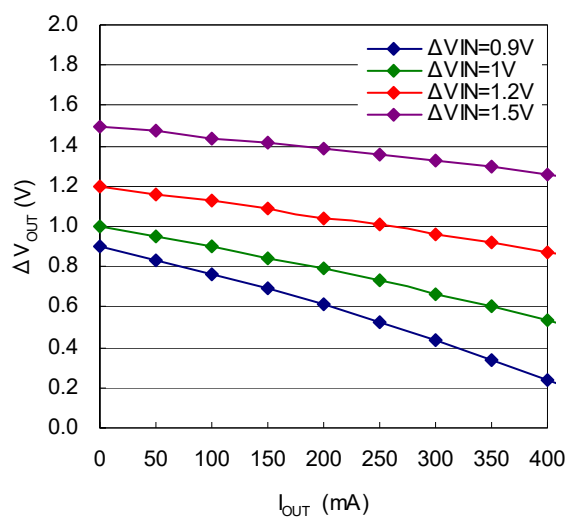

### 2. Operating Temperature vs. Supply Current (IN1=5.25V)

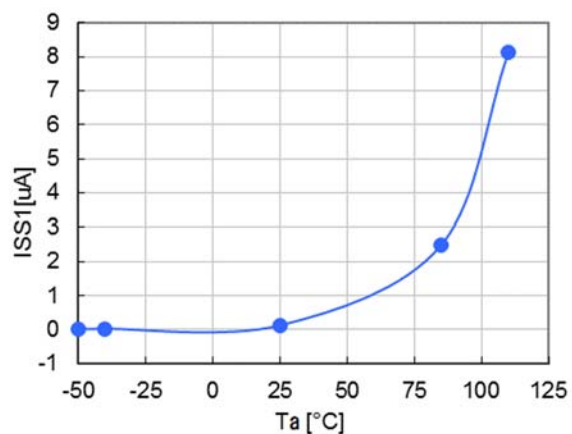

The power dissipation of the package is dependent on PCB material, layout, and environmental conditions. The following conditions are used in this measurement.

**Measurement Conditions**

Item	Standard Test Land Pattern
Environment	Mounting on Board (Wind Velocity = 0 m/s)
Board Material	Glass Cloth Epoxy Plastic (Double-Sided Board)
Board Dimensions	40 mm × 40 mm × 1.6 mm
Copper Ratio	Top Side: Approx. 50% Bottom Side: Approx. 50%
Through-holes	φ 0.5 mm × 24 pcs

**Measurement Result**

(Ta = 25°C, Tjmax = 125°C)

Item	Standard Test Land Pattern
Power Dissipation	500 mW
Thermal Resistance (θja)	θja = 200°C/W
Thermal Characterization Parameter (ψjt)	ψjt = 82°C/W

θja: Junction-to-Ambient Thermal Resistance

ψjt: Junction-to-Top Thermal Characterization Parameter

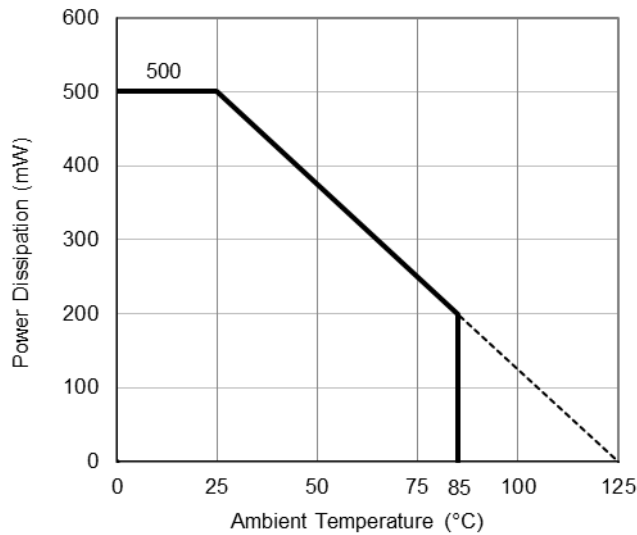

**Power Dissipation vs. Ambient Temperature**

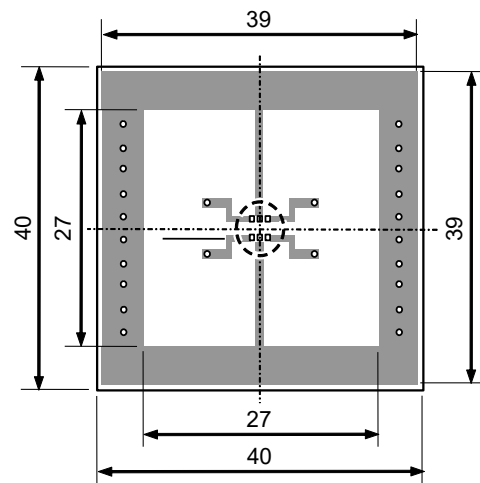

**Measurement Board Pattern**



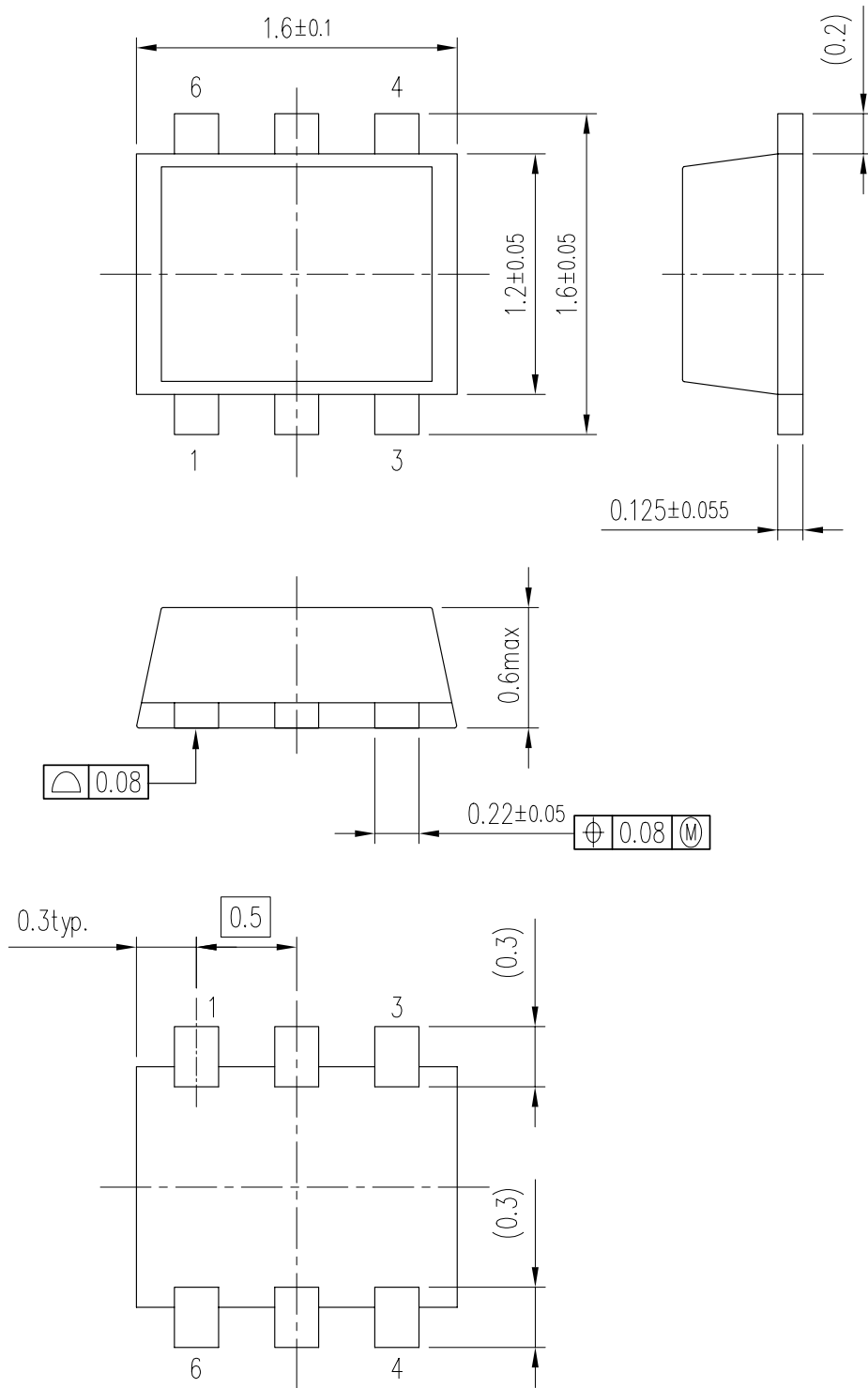

UNIT: mm

SON1612-6 Package Dimensions

The power dissipation of the package is dependent on PCB material, layout, and environmental conditions. The following measurement conditions are based on JEDEC STD. 51-7.

**Measurement Conditions**

Item	Measurement Conditions
Environment	Mounting on Board (Wind Velocity = 0 m/s)
Board Material	Glass Cloth Epoxy Plastic (Four-Layer Board)
Board Dimensions	76.2 mm × 114.3 mm × 0.8 mm
Copper Ratio	Outer Layer (First Layer): Less than 95% of 50 mm Square Inner Layers (Second and Third Layers): Approx. 100% of 50 mm Square Outer Layer (Fourth Layer): Approx. 100% of 50 mm Square
Through-holes	φ 0.3 mm × 7 pcs

**Measurement Result**

(Ta = 25°C, Tjmax = 125°C)

Item	Measurement Result
Power Dissipation	660 mW
Thermal Resistance (θja)	θja = 150°C/W
Thermal Characterization Parameter (ψjt)	ψjt = 51°C/W

θja: Junction-to-Ambient Thermal Resistance

ψjt: Junction-to-Top Thermal Characterization Parameter



**Power Dissipation vs. Ambient Temperature**



**Measurement Board Pattern**

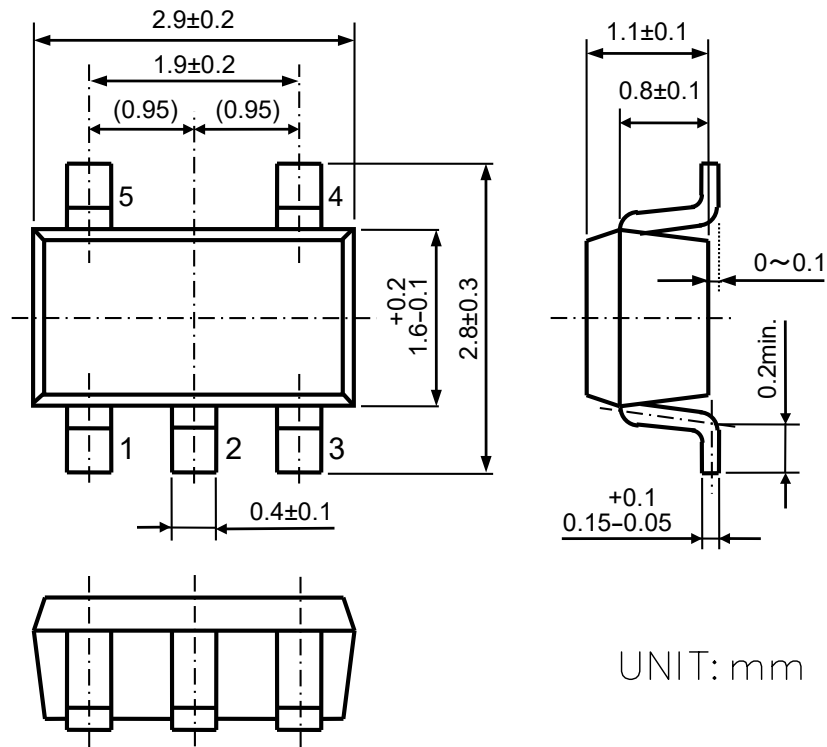

UNIT: mm

SOT-23-5 Package Dimensions



1. The products and the product specifications described in this document are subject to change or discontinuation of production without notice for reasons such as improvement. Therefore, before deciding to use the products, please refer to Ricoh sales representatives for the latest information thereon.
2. The materials in this document may not be copied or otherwise reproduced in whole or in part without prior written consent of Ricoh.
3. Please be sure to take any necessary formalities under relevant laws or regulations before exporting or otherwise taking out of your country the products or the technical information described herein.
4. The technical information described in this document shows typical characteristics of and example application circuits for the products. The release of such information is not to be construed as a warranty of or a grant of license under Ricoh's or any third party's intellectual property rights or any other rights.
5. The products listed in this document are intended and designed for use as general electronic components in standard applications (office equipment, telecommunication equipment, measuring instruments, consumer electronic products, amusement equipment etc.). Those customers intending to use a product in an application requiring extreme quality and reliability, for example, in a highly specific application where the failure or misoperation of the product could result in human injury or death (aircraft, spacevehicle, nuclear reactor control system, traffic control system, automotive and transportation equipment, combustion equipment, safety devices, life support system etc.) should first contact us.
6. We are making our continuous effort to improve the quality and reliability of our products, but semiconductor products are likely to fail with certain probability. In order to prevent any injury to persons or damages to property resulting from such failure, customers should be careful enough to incorporate safety measures in their design, such as redundancy feature, fire containment feature and fail-safe feature. We do not assume any liability or responsibility for any loss or damage arising from misuse or inappropriate use of the products.
7. Anti-radiation design is not implemented in the products described in this document.
8. The X-ray exposure can influence functions and characteristics of the products. Confirm the product functions and characteristics in the evaluation stage.
9. WLCSP products should be used in light shielded environments. The light exposure can influence functions and characteristics of the products under operation or storage.
10. There can be variation in the marking when different AOI (Automated Optical Inspection) equipment is used. In the case of recognizing the marking characteristic with AOI, please contact Ricoh sales or our distributor before attempting to use AOI.
11. Please contact Ricoh sales representatives should you have any questions or comments concerning the products or the technical information.



**Ricoh is committed to reducing the environmental loading materials in electrical devices with a view to contributing to the protection of human health and the environment.**

Ricoh has been providing RoHS compliant products since April 1, 2006 and Halogen-free products since April 1, 2012.

**RICOH** RICOH ELECTRONIC DEVICES CO., LTD.

<https://www.e-devices.ricoh.co.jp/en/>

#### Sales & Support Offices

##### **Ricoh Electronic Devices Co., Ltd.**

##### **Shin-Yokohama Office (International Sales)**

2-3, Shin-Yokohama 3-chome, Kohoku-ku, Yokohama-shi, Kanagawa, 222-8530, Japan  
Phone: +81-50-3814-7687 Fax: +81-45-474-0074

##### **Ricoh Americas Holdings, Inc.**

675 Campbell Technology Parkway, Suite 200 Campbell, CA 95008, U.S.A.  
Phone: +1-408-610-3105

##### **Ricoh Europe (Netherlands) B.V.**

##### **Semiconductor Support Centre**

Prof. W.H. Keesomlaan 1, 1183 DJ Amstelveen, The Netherlands  
Phone: +31-20-5474-309

##### **Ricoh International B.V. - German Branch**

##### **Semiconductor Sales and Support Centre**

Oberrather Strasse 6, 40472 Düsseldorf, Germany  
Phone: +49-211-6546-0

##### **Ricoh Electronic Devices Korea Co., Ltd.**

3F, Haesung Bldg, 504, Teheran-ro, Gangnam-gu, Seoul, 135-725, Korea  
Phone: +82-2-2135-5700 Fax: +82-2-2051-5713

##### **Ricoh Electronic Devices Shanghai Co., Ltd.**

Room 403, No.2 Building, No.690 Bibo Road, Pu Dong New District, Shanghai 201203,  
People's Republic of China  
Phone: +86-21-5027-3200 Fax: +86-21-5027-3299

##### **Ricoh Electronic Devices Shanghai Co., Ltd.**

##### **Shenzhen Branch**

1205, Block D (Jinlong Building), Kingkey 100, Hongbao Road, Luohu District,  
Shenzhen, China  
Phone: +86-755-8348-7600 Ext 225

##### **Ricoh Electronic Devices Co., Ltd.**

##### **Taipei office**

Room 109, 10F-1, No.51, Hengyang Rd., Taipei City, Taiwan  
Phone: +886-2-2313-1621/1622 Fax: +886-2-2313-1623