

# Temposonics®

Magnetostrictive Linear-Position Sensors

**MTS**  
SENSORS

550929 B

## Industrial Product Catalog Accessories



## EXTENSION CABLE OPTIONS

### Cable Length Limitations (Based on published Bus and Serial Communications Standards)

Apply good industry practices for long cable runs - keep cable away from high power AC lines and all motor drive cables.

R-Series Sensor Models	Baud Rate	Maximum Cable or Bus Length	
R-Series SSI	1.5 MBd	10 ft.	(3 m)
	400 kBd	160 ft.	(50 m)
	300 kBd	320 ft.	(100 m)
	200 kBd	650 ft.	(200 m)
	100 kBd	1300 ft.	(400 m)
R-Series CANbus	1.0 MBd	80 ft.	(25 m)
	500 kBd	320 ft.	(100 m)
	250 kBd	820 ft.	(250 m)
	125 kBd	1640 ft.	(500 m)
R-Series DeviceNet	500 kBd	420 ft.	(130 m)
	250 kBd	800 ft.	(270 m)
	125 kBd	1730 ft.	(530 m)
R-Series Profibus	12 MBd	330 ft.	(100 m)
	1.5 MBd	650 ft.	(200 m)
	500 kBd	1300 ft.	(400 m)
	187.5 kBd	3280 ft.	(1000 m)
	≤93.75 kBd	3940 ft.	(1200 m)

G-Series Sensor Models	Maximum Cable Length		
G-Series Analog (Voltage or Current)	150 ft.	(45 m)	
G-Series digital (PWM or Start/Stop)	300 ft.	(90 m)	Note 1
G-Series Neuter (Start/Stop output wired for square wave neuter)	250 ft.	(75 m)	Note 2

**Notes:**

- 300 feet maximum using the ± differential pair for the interrogation (Start) and gate (Stop) signals.
- 250 feet maximum using single-ended interrogation (Start) signal. The unused interrogation signal MUST be terminated to ground at the control box.

**EXTENSION CABLE OPTIONS - HOW TO ORDER**

**Standard 6-Pin connector type (D60) used with R-Series G-Series and E-Series Sensors**

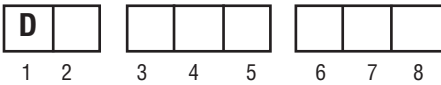

**SENSOR CONNECTION TYPE (1-2)**

- D6** = Female connector, (straight exit), and standard #530026 Cable (PVC jacket) for sensors with D6 or D60 connector
- DA** = Female connector, (90° exit), and standard # 530026 cable (PVC jacket) for sensors with D6 or D60 connector.
- DJ** = Female connector, (straight exit) and # 530045 cable, (black polyurethane jacket for higher resistance to moisture and oil), for sensors with D6 or D60 connector.
- DK** = Female connector, (90° exit), and #530045 cable, (black polyurethane jacket for higher resistance to moisture and oil), for sensors with D6 or D60 connector.

**CABLE LENGTHS\* (3-5)**

*For standard length cables up to 100 ft.*

- 005** = 5 ft.
- 015** = 15 ft.
- 025** = 25 ft.
- 050** = 50 ft.
- 100** = 100 ft.
- = Cable length (ft)\*

**CABLE TERMINATION (2 or 3 characters depending on option selected) (6-8)**

- P0** = Pigtail connection, (no connector)
- D6M** = D6 male connector, (Straight exit). Only available with the D6 option above.
- D6F** = Female connector, (straight exit). Only available with the D6 option above.
- DAF** = Female connector, (90° exit). Only available with the DA option above.

\* Refer to "Cable Length Limitations" table on page 55 for maximum cable length.

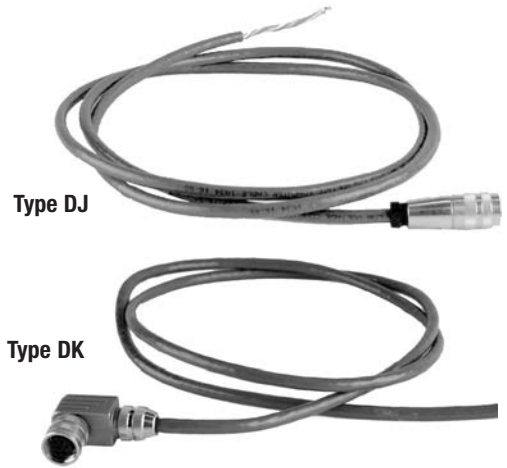

**6-Pin connector type (D63) used with R-Series Profibus Sensors**

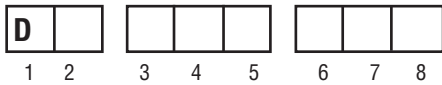

**SENSOR CONNECTION TYPE (1-2)**

- DF** = Female connector, (straight exit), and #530040 cable for Profibus sensors with D63 connector
- DG** = Female connector, (90° exit), and #530040 cable for Profibus sensors with D63 connector

**CABLE LENGTHS\* (3-5)**

*For standard length cables up to 100 ft.*

- 005** = 5 ft.
- 015** = 15 ft.
- 025** = 25 ft.
- 050** = 50 ft.
- 100** = 100 ft.
- = Cable length (ft)\*

**CABLE TERMINATION (2 or 3 characters depending on option selected) (6-8)**

- P0** = Pigtail connection, (no connector)
- DFM** = Male connector, (Straight exit). For daisy-chain connections of Profibus sensors with D63 connector. Only available with the DF option above.
- DGM** = Male connector, (90° exit). For daisy-chain connections of Profibus sensors with D63 connector. Only available with the DG option above.

\* Refer to "Cable Length Limitations" table on page 55 for maximum cable length.



## EXTENSION CABLE OPTIONS - HOW TO ORDER

### Standard 7-Pin DIN connector type (D70) used with R-Series SSI Sensors



#### SENSOR CONNECTION TYPE (1-2)

- D7** = Female connector, (straight exit), and #530029 cable (high performance shielding, orange polyurethane jacket), for SSI sensors with D70 connector.  
**DR** = Female connector, (90° exit), and #530029 cable (high performance shielding, orange polyurethane jacket), for SSI sensors with D70 connector.  
**DS** = Female connector, (straight exit) and standard #530026 cable, (PVC jacket), for SSI sensors with D70 connector.  
**DT** = Female connector, (90° exit), and standard #530026 cable, (PVC jacket), for SSI sensors with D70 connector.  
**DU** = Female connector, (straight exit), and #530045 cable, (black polyurethane jacket), for SSI sensors with D70 connector.  
**DT** = Female connector, (90° exit), and #530045 cable, (black polyurethane jacket), for SSI sensors with D70 connector.

#### CABLE LENGTHS\* (3-5)

*For standard length cables up to 100 ft.*

- 005** = 5 ft.  
**015** = 15 ft.  
**025** = 25 ft.  
**050** = 50 ft.  
**100** = 100 ft.  
--- = Cable length (ft)\*

#### CABLE TERMINATION (6-7)









- P0** = Pigtail connection, (no connector)

\* Maximum cable length is dependent on the baud rate (refer to "Cable Length Limitations" table on page 55)







Type D7

**ADAPTER CABLE OPTIONS FOR REPLACING RETIRED SENSOR MODELS (Temposonics I, II & L-SERIES)**



Product	Dimension	Application	
<b>Used when replacing Tempo II and model LH sensors that have integral RB connectors</b>			
Part no: 253243, -1, -2 Female straight exit D6 to male RB connection adapter cables 	-1	1 ft. cable length, standard	For G-Series analog output sensors
	-2	1 ft. cable length, standard	For G-Series digital-pulse and neuter output sensors
Part no: 253244, -1, -2 Female straight exit D6 to male RB connection adapter cables 	-1	5 ft. cable length	For G-Series analog output sensors
	-2	5 ft. cable length	For G-Series digital-pulse and neuter output sensors
<b>Used when replacing Tempo II sensors that have integral RC connectors</b>			
Part no: 201612, -1, -2 Female straight exit D6 to male RC connection adapter cables 	-1	1 ft. cable length, standard	For G-Series analog output sensors.
	-2	1 ft. cable length, standard	for G-Series digital-pulse and neuter output sensors.
<b>Used when replacing model LH sensors that have integral or in-line 10-pin MS connectors</b>			
Part no: 253245, -1, -2 Female straight exit D6 to male MS connection adapter cables 	-1	1 ft. cable length, standard	For G-Series analog output sensors.
	-2	1 ft. cable length, standard	For G-Series digital-pulse and neuter output sensors.
Part no: 253246, -1, -2 Female straight exit D6 to male MS connection adapter cables 	-1	5 ft. cable length	For G-Series analog output sensors
	-2	5 ft. cable length	For G-Series digital-pulse and neuter output sensors
<b>Used when replacing Tempo II and model LH sensors that have in-line MS connectors wired for the R1, R2, or R3 connection types</b>			
Part no: 253245-3 Female straight exit D6 to male MS (R1, R2, or R3 connection) adapter cables 	-3	1 ft. cable length	For R3 connection using G-series digital-pulse output sensors.
Part no: 253246-3 Female straight exit D6 to male MS (R1, R2, or R3 connection) adapter cables 	-3	5 ft. cable length	For R3 connection using G-series digital-pulse output sensors.
Part no: 253302, -1, -2 Female straight exit D6 to male MS (R1, R2, or R3 connection) adapter cables 	-1	5 ft. cable length	For R1 (positive interrogation) connection using G-Series sensors.
	-2	5 ft. cable length	For R2 (negative interrogation) connection using G-Series sensors.

**ADAPTER CABLE OPTIONS FOR REPLACING RETIRED SENSOR MODELS (Temposonics I, II & L-SERIES)**





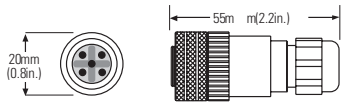

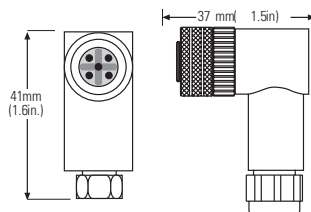



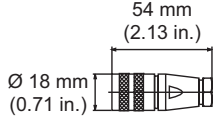

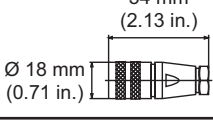

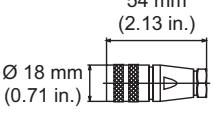

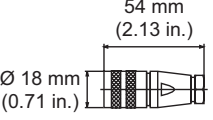

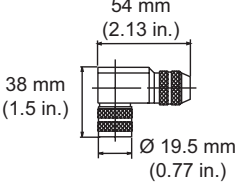
Product	Dimension	Application	
<b>Used when replacing models LH, LP and R-Series sensors that have integral RG connectors</b>			
Part no: 253248, -1, -2 Female straight exit D6 to male RG connection adapter cables 	-1	1 ft. cable length, standard	For R-Series analog or G-Series analog and digital-pulse output sensors
	-2	5 ft. cable length	For R-Series analog or G-Series analog and digital-pulse output sensors
Part no: 253315, -1, -2 Female straight exit D7 to male RG connection adapter cables 	-1	1 ft. cable length, standard	For R-Series SSI output sensors
	-2	5 ft. cable length	For R-Series SSI output sensors
<b>Used when replacing model LP sensors that have the integral C-style connector or in-line H or J style connectors</b>			
Part no: 253247, -1, -2, -3, -4 Female straight exit D6 to male AMP connection adapter cables. 	-1	1 ft. cable length	For G-Series analog output sensors
	-2	1 ft. cable length	For G-Series digital-pulse output sensors
	-3	7 ft. cable length	For G-Series analog output sensors
	-4	7 ft. cable length	For G-Series digital-pulse output sensors

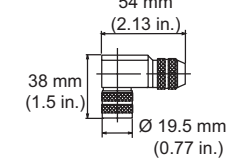
Product	Dimension	Application
Part no. 401327 Male RC to female RB connector adapter. 	6 in. overall length	For retrofitting RC connection style Temposonics II or model LH sensors

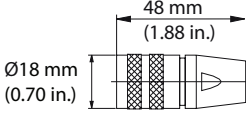

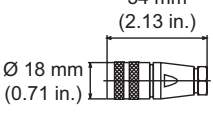

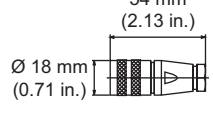

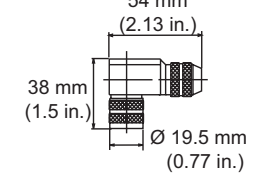
**CONNECTORS (For Current Production Sensors)**

Product	Dimension	Material	Application
<b>5-pin style connectors</b>			
Part no. 370375 D51 Field-installable connector 			Female, straight exit, for Model R-Series sensors with DeviceNet output
Part no. 370376 D51 Field-installable connector 			Female, 90° exit, for Model R-Series sensors with DeviceNet output

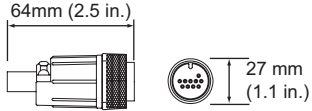
**CONNECTORS (For Current Production Sensors)**

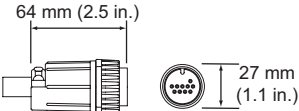

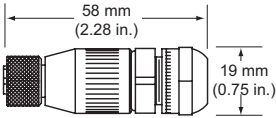

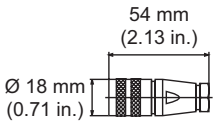





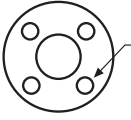

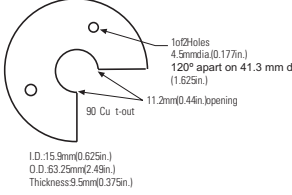

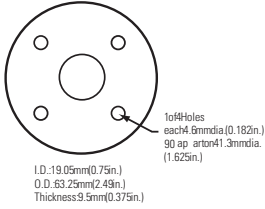
Product	Dimension	Material	Application
<b>6-pin style connectors</b>			
Part no. 560700 D6 Field-installable connector 		Housing: Zinc nickel plated Termination: Solder Contact insert: Silver plated Cable clamp: PG7	Female, straight exit, mates to D60 connection type on R-Series, G-Series & E-Series sensors with six conductor cable (STC09131D)
Part no. 370372 D6 Field-installable connector 		Housing: Zinc nickel plated Termination: Solder Contact insert: Silver plated Cable clamp: PG7	Male, straight exit
Part no. 370423 D6 Field-installable connector 		Housing: Zinc nickel plated Termination: Solder Contact insert: Silver plated Cable clamp: PG9 Max. cable dia.: 8mm	Female, for Profibus sensors w/PG9 strain relief (D63 connection type). Also used to retrofit 10 conductor Tempo II extension cables (STC09131D06PG9)
Part no. 370427 D6 Field-installable connector 		Housing: Zinc nickel plated Termination: Solder Contact insert: Silver plated Cable clamp: PG9 Max. cable dia.: 8mm	Male, for Profibus sensors w/PG9 strain relief (D63 connection type) (STC09131H06PG9)
Part no. 560778 D6 Field-installable connector 		Housing: Zinc nickel plated Termination: Solder Contact insert: Silver plated Cable clamp: PG9, M16 Max. cable dia.: 8 mm	Female, 90° exit, mates to D60 & Profibus D63 connection type on R-Series, G-Series & E-Series sensors with six conductor cable (STC09131-6)
Part no. 370460 Profibus D6 Field-installable connector 		Housing: Zinc nickel plated Termination: Solder Contact insert: Silver plated Cable clamp: PG9 Max. cable dia.: 8mm	Male, 90° exit, for Profibus sensors (D63 connection type) (STC09131H06PG9)
Part no. 252347* Profibus bus terminator * was 370419 (STA09131H06) 		Housing: Zinc nickel plated Termination: Solder Contact insert: Silver plated	For use with Model RH, RP & RF sensors, Male connector type
<b>7-pin style connectors</b>			
Part no. 560701 D7 Field-installable connector 		Housing: Zinc nickel plated Termination: Solder Contact insert: Silver plated Cable clamp: PG7	Female, Straight exit, mates to D70 connection type on R-Series sensors. Connector has PG7 size strain relief for standard cable.
Part no. 370516 D7 Field-installable connector 		Housing: Zinc nickel plated Termination: Solder Contact insert: Silver plated Cable clamp: PG9 Max. cable dia.: 8mm	Female, straight-exit, mates to D7 connection type on R-Series SSI sensors. Connector has PG9 size strain-relief for larger cable size, (STC09131D07PG9)
Part no. 560779 D7 Field-installable connector 		Housing: Zinc nickel plated Termination: Solder Contact insert: Silver plated Cable clamp: PG9, M16 Max. cable dia.: 8 mm	Female, 90° exit, mates to D70 connection type on R-Series sensors (STC09131-7)

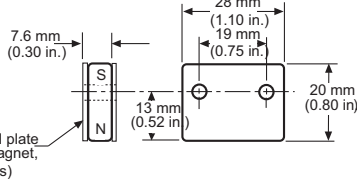
**CONNECTORS (For Retired Sensor Models)**

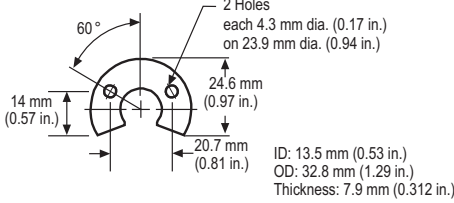

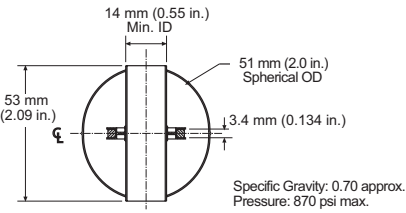

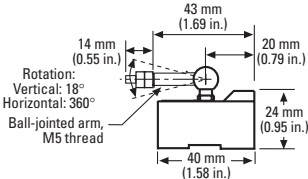

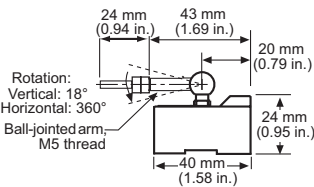



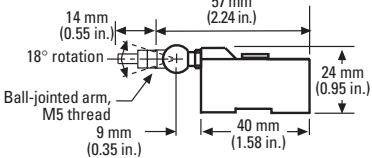

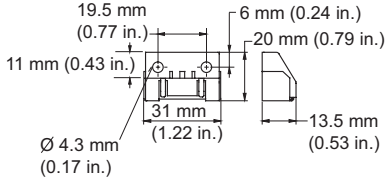
Product	Dimension	Material	Application
<p>Part no. 400755-3 RB/RC connector, Field-installable</p> 			<p>Female field-installable, mates with sensor fitted with RB connector or previous RC design</p>
<p>Part no. 370486 RB connector</p> 			<p>Male, field-installable mates with part no: 400755-3</p>
<p>Part no. 401366 RG Field-installable connector</p> 			<p>Female, straight exit mates to RG connection type on R-Series and L-Series</p>
<p>Part no. 370391 D8 Field-installable connector</p> 		<p>Housing: Zinc nickel plated Termination: Solder Contact insert: Silver plated Cable clamp: PG7</p>	<p>Female, straight exit, mates to D80 connection type on Model L Series</p>



**MAGNETS AND FLOATS**

Product	Dimension	Material	Application
Part no. 201542-2 Standard ring magnet 	 <p>4 Holes each 4.3 mm dia. (0.17 in.) 90° apart on 23.9 mm dia. (0.94 in.)</p> <p>ID: 13.5 mm (0.53 in.) OD: 32.8 mm (1.29 in.) Thickness: 7.9 mm (0.312 in.)</p>	Composite PA-Ferrite-GF20 Weight: Approx. 14g Operating temperature: -40 to +100°C	For Model RH, GH
Part no. 201553 Large open-ring magnet 	 <p>10#Holes 4.5mm dia (0.177 in.) 120° apart on 41.3 mm d (1.625 in.)</p> <p>90 Cu t-out 11.2mm (0.44 in.) opening</p> <p>I.D. 15.9mm (0.625 in.) O.D. 63.25mm (2.49 in.) Thickness 9.5mm (0.375 in.)</p>	PA 66-GF30 Magnet slugs potted with epoxy Weight: Approx. 26g Operating temperature: -40 to +75°C	For Model RH, GH
Part no. 201554 Large ring magnet 	 <p>10#Holes each 4.6mm dia (0.182 in.) 90° apart on 41.3mm dia. (1.625 in.)</p> <p>I.D. 19.05mm (0.75 in.) O.D. 63.25mm (2.49 in.) Thickness 9.5mm (0.375 in.)</p>	PA 66-GF30 Magnet slugs potted with epoxy Weight: Approx. 35g Operating temperature: -40 to +75°C	For Model RH, GH
Part no. 251298-2 Bar Magnet 	 <p>7.6 mm (0.30 in.)</p> <p>28 mm (1.10 in.) 19 mm (0.75 in.)</p> <p>13 mm (0.52 in.)</p> <p>20 mm (0.80 in.)</p> <p>Stainless-steel plate (bonded to magnet, both sides)</p>		For Model RH, RP, GH, GP, EP
Part no. 251416-2 Standard open ring magnet 	 <p>2 Holes each 4.3 mm dia. (0.17 in.) on 23.9 mm dia. (0.94 in.)</p> <p>60°</p> <p>14 mm (0.57 in.)</p> <p>24.6 mm (0.97 in.)</p> <p>20.7 mm (0.81 in.)</p> <p>ID: 13.5 mm (0.53 in.) OD: 32.8 mm (1.29 in.) Thickness: 7.9 mm (0.312 in.)</p>	Composite PA-Ferrite-GF20 Weight: Approx. 11g Operating temperature: -40 to +100°C	For Model RP, RH, GH, GP, EP
Part no. 251447 Magnet float 	 <p>14 mm (0.55 in.) Min. ID</p> <p>51 mm (2.0 in.) Spherical OD</p> <p>3.4 mm (0.134 in.)</p> <p>53 mm (2.09 in.)</p> <p>Specific Gravity: 0.70 approx. Pressure: 870 psi max.</p>	316L Stainless steel Density: 720 kg/m <sup>3</sup> Max. Pressure: 870 psi Weight: 42 ± 3g	For Model RH, GH
Part no. 252182 Captive-sliding magnet 	 <p>43 mm (1.69 in.)</p> <p>20 mm (0.79 in.)</p> <p>14 mm (0.55 in.)</p> <p>24 mm (0.95 in.)</p> <p>40 mm (1.58 in.)</p> <p>Rotation: Vertical: 18° Horizontal: 360°</p> <p>Ball-jointed arm, M5 thread</p>	GFK, Magnet hard ferrite Weight: Approx. 30g Operating temperature: -40 to +75°C	For Model RP, GP, EP
Part no. 252183 Captive-sliding magnet 	 <p>24 mm (0.94 in.)</p> <p>43 mm (1.69 in.)</p> <p>20 mm (0.79 in.)</p> <p>24 mm (0.95 in.)</p> <p>40 mm (1.58 in.)</p> <p>Rotation: Vertical: 18° Horizontal: 360°</p> <p>Ball-jointed arm, M5 thread</p>	GFK, magnet hard ferrite Weight: Approx. 30g Operating temperature: -40 to 75° C	For Model RP, GP, EP Similar to (252182) but with extra length on the ball-jointed arm

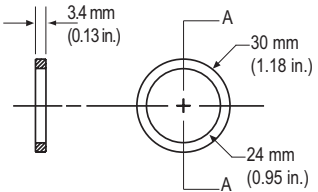
**MAGNETS AND FLOATS**

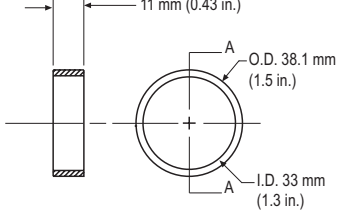
Product	Dimension	Material	Application
Part no. 252184 Captive-sliding magnet 	 <p>14 mm (0.55 in.)                      57 mm (2.24 in.)                      18° rotation                      Ball-jointed arm, M5 thread                      9 mm (0.35 in.)                      24 mm (0.95 in.)                      40 mm (1.58 in.)</p>	GFK, magnet hard ferrite Weight: Approx. 30g Operating temperature: -40 to 75° C	For Model RP, GP, EP
Part no. 252887 Block magnet type L 	 <p>19.5 mm (0.77 in.)                      6 mm (0.24 in.)                      20 mm (0.79 in.)                      11 mm (0.43 in.)                      31 mm (1.22 in.)                      13.5 mm (0.53 in.)                      Ø 4.3 mm (0.17 in.)</p>		For Model EP, EP2
Part no. 400533 Small ring magnet 	 <p>I.D. 13.5 mm (0.53 in.)                      O.D. 25.4 mm (1.0 in.)                      Thickness: 7.9 mm (0.312 in.)</p>	Composite: PA-Ferrite Weight: Approx. 10g Operating temperature: -40 to +100° C	For Model RH, GH
Part no. 400633 Magnet spacer 	 <p>4 Holes each 3.9 mm O.D. (0.15 in.)                      90° apart on 23.9 mm O.D. (0.94 in.)                      I.D. 14.3 mm (0.56 in.)                      O.D. 31.8 mm (1.25 in.)                      Thickness: 3.2 mm (0.125 in.)</p>	Aluminum	For Model RH, GH. Non-ferrous spacer for use with standard ring magnet (201542-2)
Part no. 401032 Small ring magnet 	 <p>I.D. 13.5 mm (0.532 in.)                      O.D. 17.4 mm (0.685 in.)                      Thickness: 7.9 mm (0.312 in.)                      (For use with strokes ≤1525 mm or 60 in.)</p>	Surface PA coated Weight: Approx. 5g Operating temperature: -40 to +100° C	For Model RH, GH. Not for multi-position measurement. Resolution min. 10 µm
Part no. 401467 Large ring magnet 	 <p>34 mm (1.33 in.)                      30 mm (1.18 in.)                      24 mm (0.95 in.)                      A</p>	Composite: PA-Ferrite Operating temperature: -40 to +100° C	For Model RH, GH
Part no. 401468 Large ring magnet 	 <p>11 mm (0.43 in.)                      O.D. 38.1 mm (1.5 in.)                      I.D. 33 mm (1.3 in.)                      A</p>	Composite: PA-Ferrite Operating temperature: -40 to +100° C	For Model RH, GH

## MAGNETS, FLOATS, AND PRESSURE HOUSING

### Compatibility Chart

Magnet Part no.	Sensor Model				
	Rod-style		Profile-style		
	RH	GH	RP	GP	EP
201542-2	•	•			
201553	•	•			
201554	•	•			
201298-2	•	•	•	•	•
251416-2	•	•	•	•	•
251447 (float)	•	•			
252182			•	•	•
252183			•	•	•
252184			•	•	•
400533	•	•			
401032	•	•			
401467	•	•			
401468	•	•			

### HOW TO ORDER

#### Pressure Housing (for use with Temposonics sensor models GH and RH only)

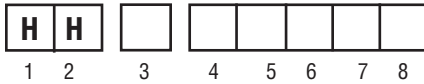

#### HOUSING STYLE (3)





- T** = US customary threads, raised-faced hex
- S** = US customary threads, flat-faced hex
- M** = Metric threads, flat-faced hex

#### STROKE LENGTH (4-8)\*



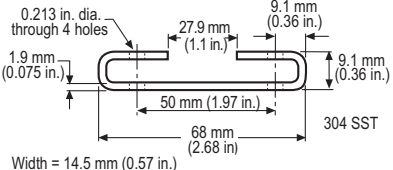

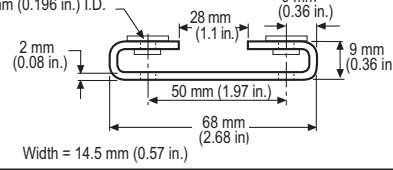

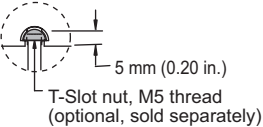
- U = Inches and tenths (Encode in 0.1 in. increments)  
or
- M = Millimeters (Encode in 5 mm increments)

\* Limited to 1825 mm (72 in.)

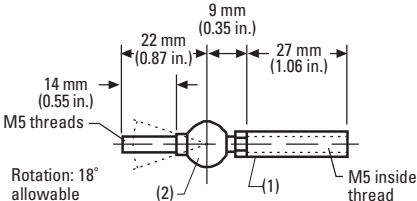
**MOUNTING FEET AND T-SLOT NUT**

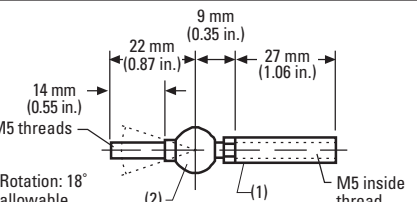

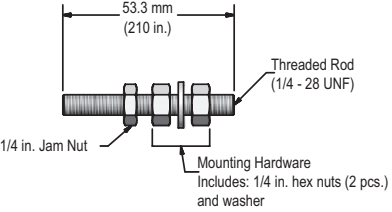

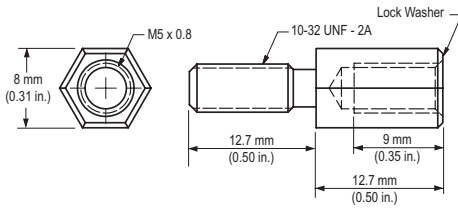
Product	Dimension	Material	Application
Part no. 400802 Mounting feet, standard 		304 Stainless steel	For use with Model RP, GP, EP and ER sensors.
Part no. 252004 Mounting feet, insulated 		Stainless steel with nylon washers and cloth tape on bottom	For use with Model RP, GP, and EP sensors. Provides electrical and mechanical isolation.
Part no. 401602 Base channel T-slot nut 		M5 thread	Nut for mounting RP and GP sensors.

**MECHANICAL END CONNECTORS (FOR USE WITH TEMPOSONICS SENSOR MODELS RP, GP, EP AND ER)**

Product	Dimension	Material	Application
Part no. 401603 Joint-rod sleeve (1 in.) 			For use with captive-sliding magnets
Part no. 401913* Ball-jointed arm, straight 			For use with captive-sliding magnets
Part no. 251975 Stud end attachment 			For use with Model ER sensors
Part no. 402849 Thread adapter, 10-32 male to M5 female 		Stainless Steel	This part can be used with Models EP, GP, or RP captive-sliding magnets when retrofitting old LPS model sensors that have the old 252052 captive-sliding magnet (with #10-32 male threads).

**MECHANICAL END CONNECTORS (FOR USE WITH TEMPOSONICS SENSOR MODELS RP, GP, EP AND ER)**

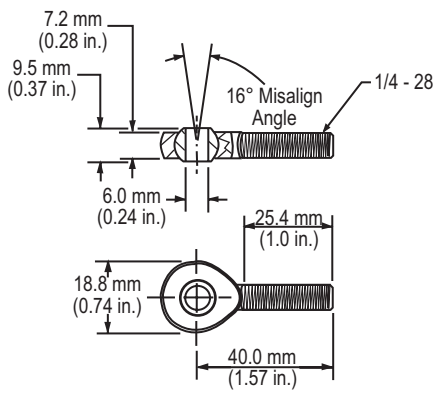

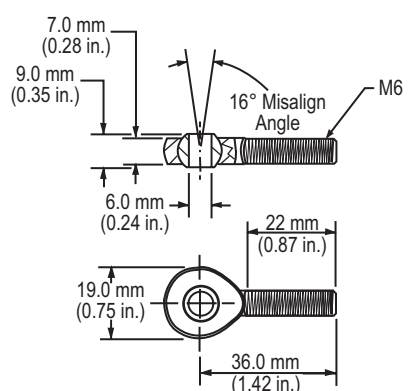



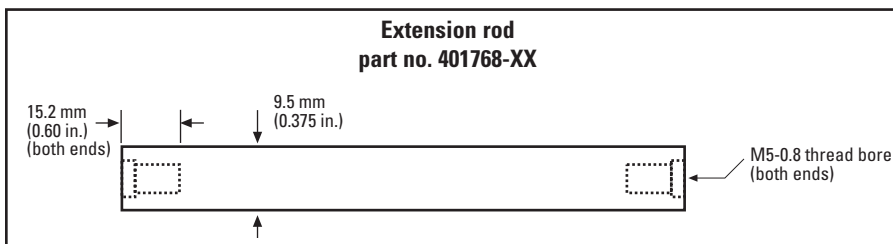

Accessories

Product	Dimension	Application
Part no. 253346 Rod end kit (English) 	See Part no. 560444	Male 1/4-28 rod ends (2 pieces), plus special wrench for use with Model ER sensors.
Part no. 253347 Rod end kit (Metric) 	See Part no. 561255	Male M6 rod ends (2pieces), plus special wrench for use with Model ER sensors.
Part no. 560444 Rod end attachment (English) 		Male 1/4-28 for use with Model ER sensors.
Part no. 561255 Rod end attachment (Metric) 		Male M6 for use with Model ER sensors.

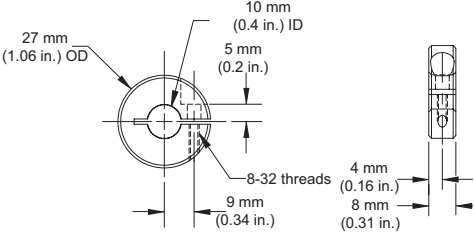
<i>Extension rod lengths</i>	<i>Part no.</i>	<i>Extension rod lengths</i>	<i>Part no.</i>
60.3 mm (2.375 in.)	401768-2	390.5 mm (15.375 in.)	401768-15
85.7 mm (3.375 in.)	401768-3	466.7 mm (18.375 in.)	401768-18
111.1 mm (4.375 in.)	401768-4	517.5 mm (20.375 in.)	401768-20
161.9 mm (6.375 in.)	401768-6	542.9 mm (21.375 in.)	401768-21
187.3 mm (7.375 in.)	401768-7	619.1 mm (24.375 in.)	401768-24
212.7 mm (8.375 in.)	401768-8	771.5 mm (30.375 in.)	401768-30
238.1 mm (9.375 in.)	401768-9	923.9 mm (36.375 in.)	401768-36
263.5 mm (10.375 in.)	401768-10	1076.3 mm (42.375 in.)	401768-42
314.3 mm (12.375 in.)	401768-12	1228.7 mm (48.375 in.)	401768-48
365.1 mm (14.375 in.)	401768-14	1533.5 mm (60.375 in.)	401768-60

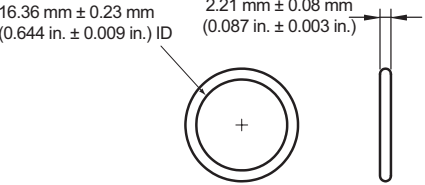

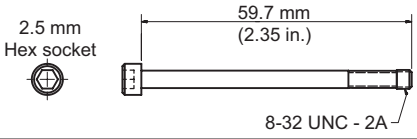
**MISCELLANEOUS INSTALLATION HARDWARE**

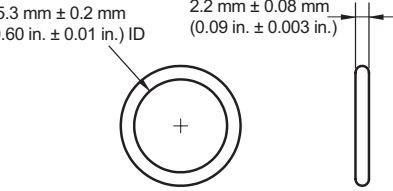
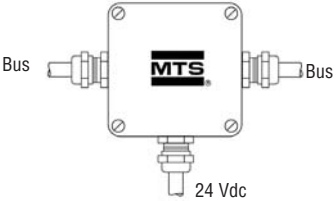
Product	Dimension	Material	Application
Part no. 500015 Hex jam-nut 	3/4-16 in. UNC	Stainless steel, nylon insert	3/4-16 UNF Nylon insert locknut for use with model RH and GH sensors with style "T" or "S" housings.
Part no. 500018 Hex jam-nut 	M18 x 1.5 threads	Stainless steel	M18 x 1.5 nut for use with models RH and GH sensors with style "M" housing.
Part no. 560777 Collar 	 <p>27 mm (1.06 in.) OD                      10 mm (0.4 in.) ID                      5 mm (0.2 in.)                      8-32 threads                      9 mm (0.34 in.)                      4 mm (0.16 in.)                      8 mm (0.31 in.)</p>	304 stainless steel	For use with GH and RH pressure housings and float 251447.
Part no. 560315 O-Ring, for US customary flange with 3/4-16 UNF threads 	 <p>16.36 mm ± 0.23 mm (0.644 in. ± 0.009 in.) ID                      2.21 mm ± 0.08 mm (0.087 in. ± 0.003 in.)</p>	Fluoroelastomer 75 ± 5 durometer	Spare, for use with rod-style sensor Models RH and GH. With style "T" or "S" housing.
Part no. 560357 Magnet mounting screws 		#6-32x7/8 Stainless steel	Used to mount standard ring magnet part no: 201542-2 (4 required) or open ring magnet part no: 251416-2 (2 required).
Part no. 402617 Electronics housing screw 	 <p>2.5 mm Hex socket                      59.7 mm (2.35 in.)                      8-32 UNC - 2A</p>		Used to install newer sensor cartridges (GHB and RHB models) into the old LH or old RH sensor pressure housings (2 required).
Part no. 401133 O-Ring, for metric flange with M18 x 1.5 threads. 	 <p>15.3 mm ± 0.2 mm (0.60 in. ± 0.01 in.) ID                      2.2 mm ± 0.08 mm (0.09 in. ± 0.003 in.)</p>	Fluoroelastomer 75 ± 5 durometer	Spare, for use with rod-style sensor Models RH and GH with style "M" housing.
Part no. 252916 Profibus filter box 			Dimensions: 80 mm (3.15 in.) long x 75 mm (2.95 in.) wide x 58 mm (2.28 in.) deep. The box is used for EMC-conformal feeding of 24 Vdc supply voltage into the Profibus-DP hybrid cable.



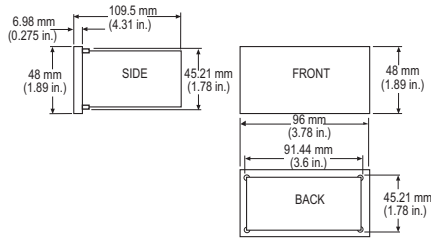



## SENSOR DISPLAY

Product	Dimension	Application
Part no. 251153 Temposonics Display Unit (TDU-200)* 		Meter for use with Start/Stop sensors only.
<b>Note:</b> *Product Specification 550178 and User's Manual 550260.		





## POWER SUPPLY

Product	Dimension	Application
Part no: 380009 Sensor power supply 	100 mm x 165 mm x 50 mm.	Standard power supply (110 Vac to 24 Vdc/ 0.5 A) for use with sensors and interface products.



## SENSOR PROGRAMMING

Product	Application
Part no. 253124 R-Series analog hand-held programmer 	For adjusting null (setpoint 1) and span (setpoint 2) on R-Series analog sensors, (for single magnet versions only).
Part no. 253408 R-Series analog cabinet programmer 	For adjusting null (setpoint 1) and span (setpoint 2) on R-Series analog sensors, (for single magnet versions only). The programmer is designed for snap-in mounting on standard 35 mm DIN rail. A "program/run" switch allows the programmer to be permanently wired inside the control cabinet.
Part no. 253309 R-Series analog PC programming kit 	Interface converter box, power supply, PC software and cabling.
Part no. 253310 R-Series SSI PC programming kit 	Interface converter box, power supply, PC software and cabling.
Part no. 252173-D63 R-Series Profibus node address programmer 	For field address programming of R-Series Profibus output.
Part no. 252173-D53 R-Series Profibus programming accessories 	For field address programming of R-Series Profibus output.
Part no. 252382-D62 R-Series CANbus programming accessories 	For field address programming of R-Series CANopen sensors.

## SENSOR PROGRAMMING

Product	Application
Part no. 253294 G-Series analog hand-held programmer 	For adjusting null (setpoint 1) and span (setpoint 2) on G-Series analog sensors.
Part no. 380078 G-Series infrared setpoint programmer 	For adjusting null (setpoint 1) and span (setpoint 2) on G-Series analog sensors.
Part no. 253311 G-Series analog PC programming kit 	Interface converter box, power supply, PC software and cabling.
Part no. 253312 G-Series digital pulse PC programming kit 	Interface converter box, power supply, PC software and cabling.
Part no. 401727 Profibus master simulator 	Can be used to check the sensors functions and to change the slave address. Allows the magnet positions and diagnostic data to be read.

## FIELD SETUP SOFTWARE

Product	Application
Part no. 551033 G-Series documentation and software CD 	Includes G-Series PC setup software (part no: 625060)* G-Series Palm OS software (part no: 625061)*, G-Series User's Manual (part no: 550966) and additional documentation.
Part no. 551052 R-Series documentation and software CD 	Includes R-Series PC setup software (part no: 625064)*, parameter files and product documentation.

**Note:**

\* Download software from our website ([www.mtssensors.com](http://www.mtssensors.com))



**Part Number: 09-06 550929 Revision B**

MTS and Temposonics are registered trademarks of MTS Systems Corporation.  
All other trademarks are the property of their respective owners.

All Temposonics sensors are covered by US patent number 5,545,984. Additional patents are pending.  
Printed in USA. Copyright © 2006 MTS Systems Corporation. All Rights Reserved.

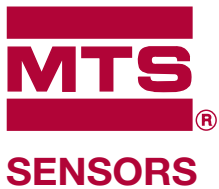

**UNITED STATES**  
**MTS Systems Corporation**  
Sensors Division  
3001 Sheldon Drive  
Cary, NC 27513  
Tel: (800) 633-7609  
Fax: (919) 677-0200  
(800) 498-4442  
[www.mtssensors.com](http://www.mtssensors.com)  
[sensorsinfo@mts.com](mailto:sensorsinfo@mts.com)

**GERMANY**  
**MTS Sensor Technologie**  
GmbH & Co. KG  
Auf dem Schüffel 9  
D - 58513 Lüdenscheid  
Tel: +49 / 23 51 / 95 87-0  
Fax: +49 / 23 51 / 56 491  
[www.mtssensor.de](http://www.mtssensor.de)  
[info@mtssensor.de](mailto:info@mtssensor.de)

**JAPAN**  
**MTS Sensors Technology**  
Corporation  
Ushikubo Bldg.  
737 Aihara-cho, Machida-shi  
Tokyo 194-0211, Japan  
Tel: + 81 (42) 775 / 3838  
Fax: + 81 (42) 775 / 5516  
[www.mtssensor.co.jp](http://www.mtssensor.co.jp)  
[info@mtssensor.co.jp](mailto:info@mtssensor.co.jp)